

Profilabwicklung Objekt 1 und 2 (1:3)

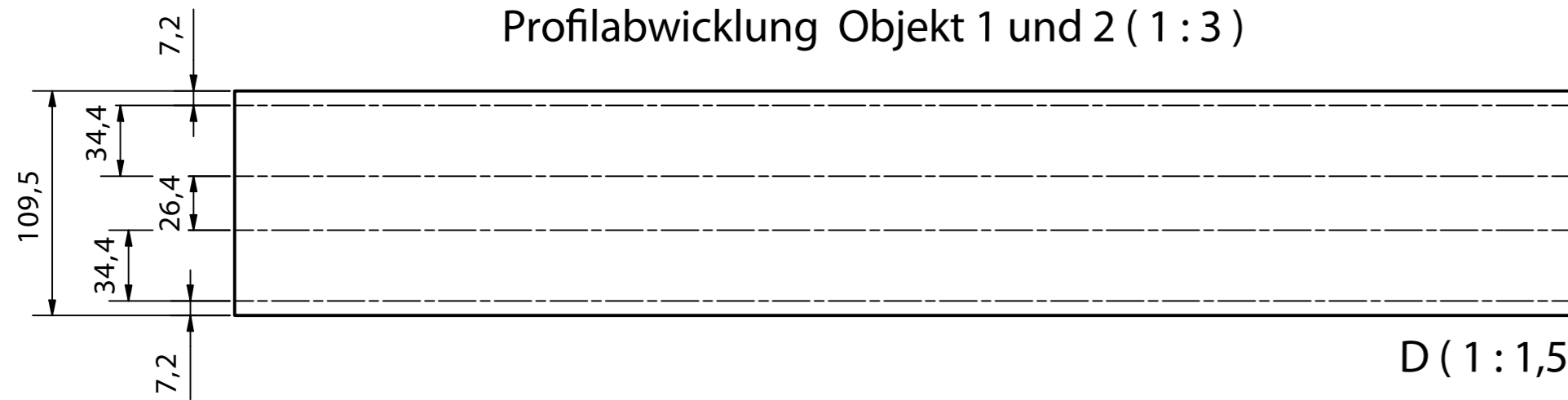

D (1:1,5)

Befestigungsblech (1:1)

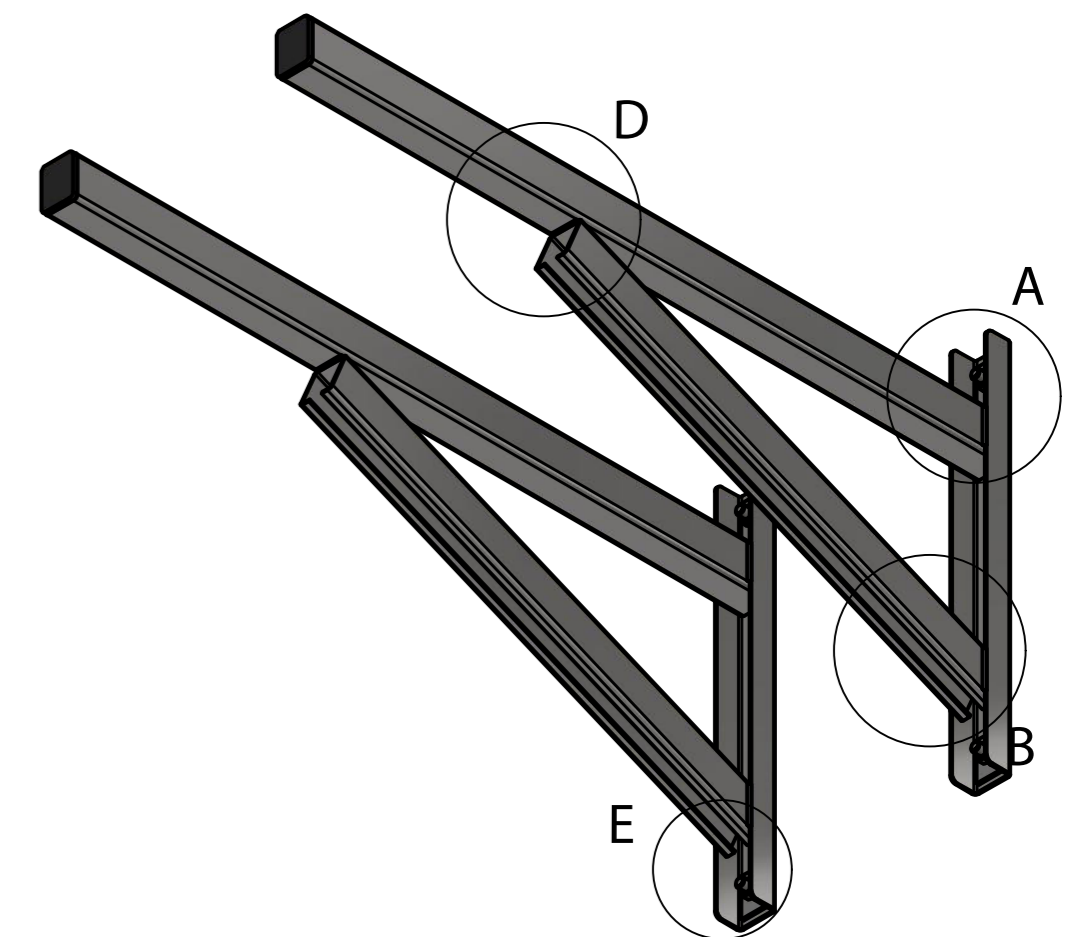
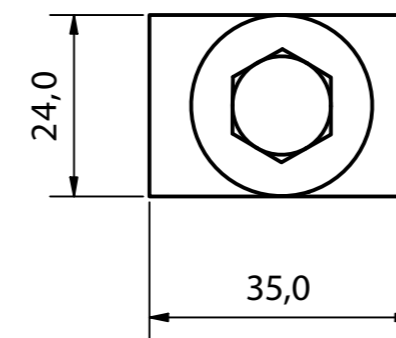
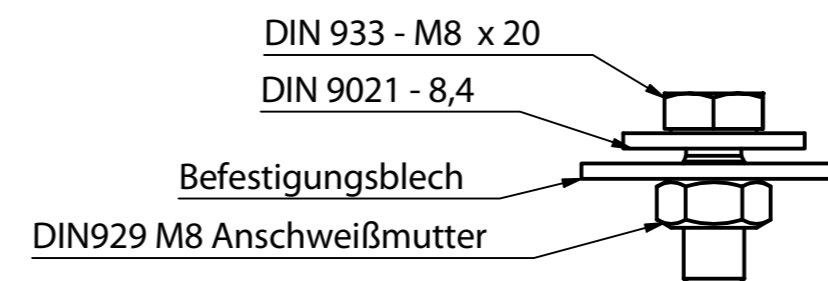

A (1:1,5)

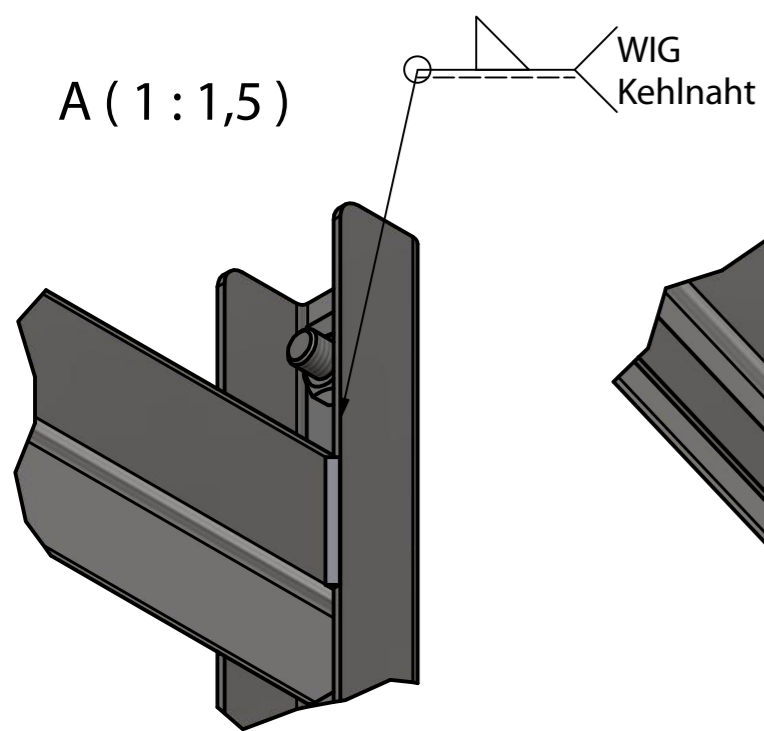

B (1:1,5)

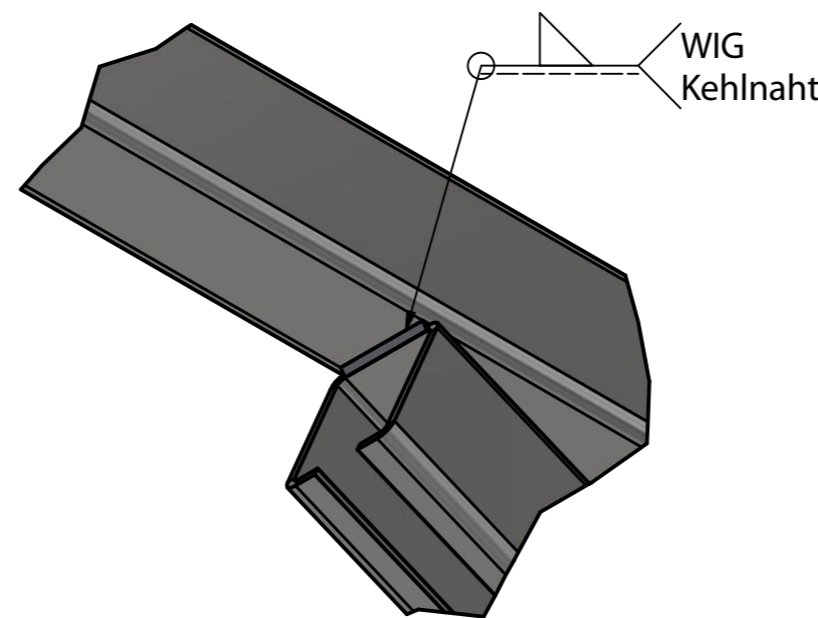
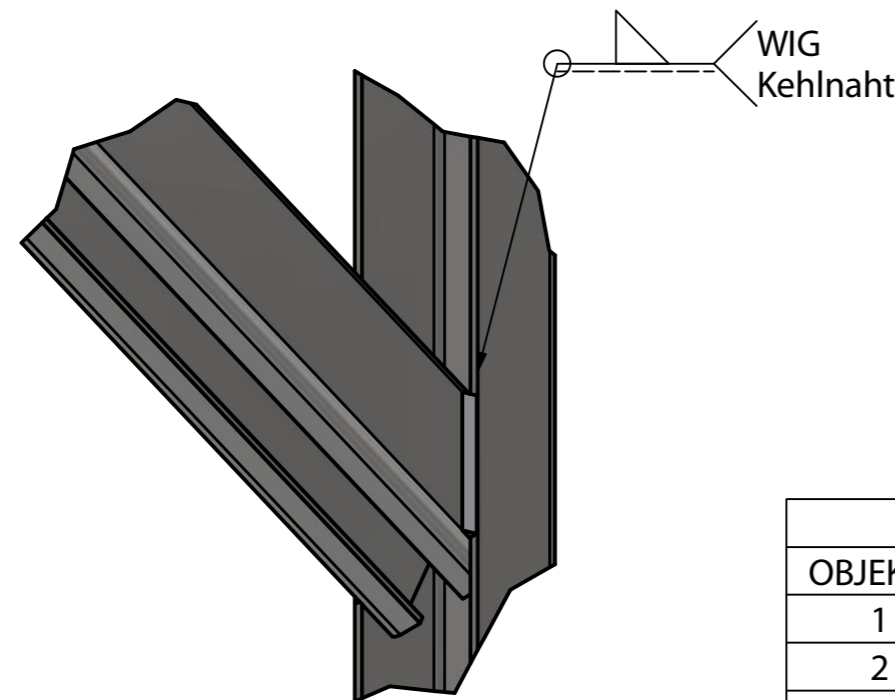

BAUTEILLISTE Baugruppe (Auslieferung)			
OBJEKT	ANZAHL	BAUTEILNUMMER	MASSE
1	2	WKON 1000000001 L=650	2,349 kg
2	4	Befestigungsblech 1.4301 2,0	0,013 kg
3	4	DIN 933 - M8 x 20	0,013 kg
4	4	DIN 929 - M8 Anschweißmutter	0,005 kg
5	2	Abdeckung	0,009 kg
6	4	DIN 9021 - 8,4 70SM4003	0,006 kg

BAUTEILLISTE Stück Konsole				
OBJEKT	ANZAHL	BAUTEILNUMMER	MATERIAL	MASSE/Stück
1	2	Schiene	1.4301 - 2,0 matt	1,162 kg
2	2	Stützprofil	1.4301 - 2,0 matt	0,771 kg
3	2	Wandprofil	1.4301 - 2,0 matt	0,413 kg

Schornsteintechnik Neumarkt

Werkstoff: Edelstahl AISI 440C, geschweißt Gewicht: 2,349 kg

Bezeichnung: Wandkonsole Typ 650 mm

Zeichnungsnummer: xxxxx Artikelnummer: 20-Ø-835

1/1

A2